

RDM 2000-SD



The RDM 2000-SD is a machine designed for the packaging of single use products into 4 side-seal pouches. The range of packing material supported is comprehensive: papers, aluminum & plastic foils. Human interface is through a large colored tactile screen which allows programming of sealing parameters and reports any fault conditions. The machine is fully auto-controlled with automatic cycle interruption when an alarm threshold is crossed. This continuous running machine is fully driven by SIEMENS brushless motorization.

Features:

- Length of pouches adjustable from 80 to 2 000 mm through tactile screen,
- Width of pouches adjustable from 60 to 220 mm (or 320 or 450 mm)
- Height of product up to 25 mm
- Production rate up to 150 cycles/minute & per lane
- **100% Made in France – Conformity CE**

Included Equipment:

- Direct access calibration connectors
- Peel open flap
- Photocell for pre-printed material
- Sealing tools for specific shapes if required
- Digital display of sealing pressure
- Pneumatic mandrel for tension control of material
- Hygienic loading table: with pushers or with direct loading onto the lower web of material.

JR-Maruani

MANUFACTURER OF
PACKAGING MACHINES

HORIZONTAL 4 SIDE-SEAL PACKAGING MACHINE



Optional equipment:

Printing device and/or Labeler
Tear open notch
Round corners
Vacuum packing
Edge trimming system
Automatic dispenser
Stacking device

Thumb notch
Hanging hole
Selective reject gate
Double registration for pouches printed on both sides
Synchronization with production machine
Full production & packaging lines

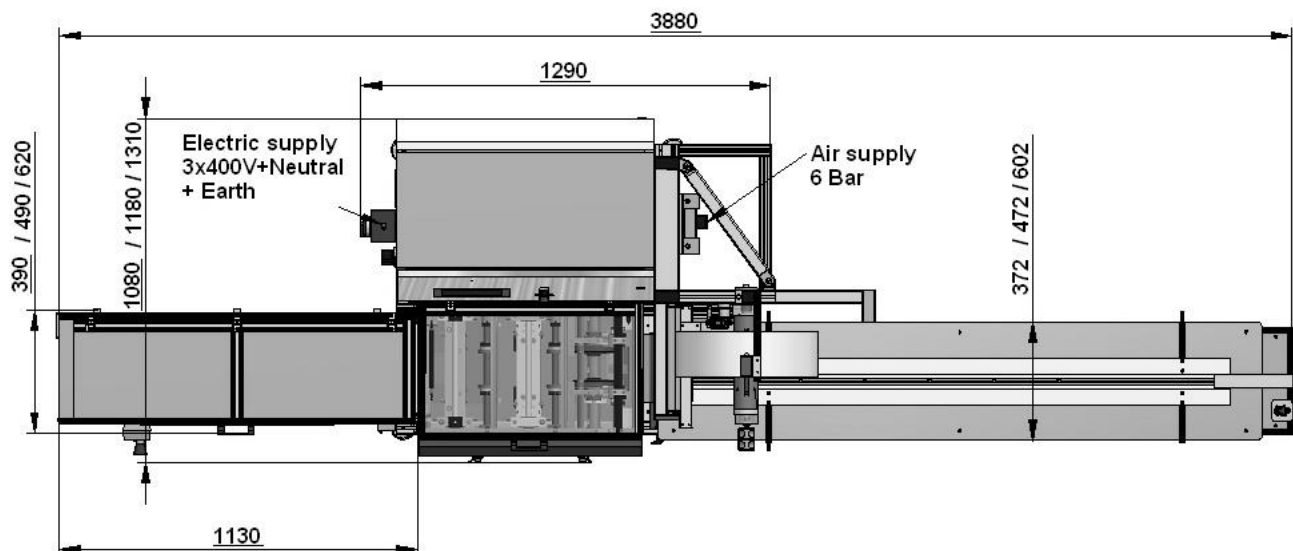
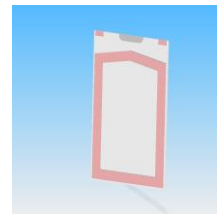
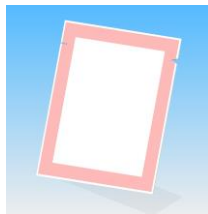

Dimensions of machines type RDM 2000.SD / SD.W / SD.XW
Useful width of 220 / 320 / 450 mm

ETS J.R. MARUANI – ZI, 11 rue des Cressonnères – 95500 Gonesse France
Tél. +33 (0) 1 39 87 52 66 – Fax. +33 (0) 1 39 87 09 19 – e.mail: jrmaruani@aol.com - Web.
www.jrmaruani.com